



Designing and Fabrication of Switching High Voltage Power Supply for Nuclear Medicine Imaging Systems

M. Moradi^{1,*}, Z. Arvaneh²

¹ Department of Medicine Engineering, Shahid Beheshti University, Tehran, Iran

² Department of Power Engineering, Islamic Azad University, Ilam, Iran

ARTICLE INFO	ABSTRACT
<p>Article History: Received 29 January 2019 Received in revised form 4 February 2019 Accepted 2 March 2019 Available online 3 March 2019</p>	<p>This paper describes design considerations of the High voltage (HV) module with low ripple and good stability in order to improve the efficiency of nuclear imaging systems consist of Single Photon Emission Computed Tomography (SPECT). In the design of the current HV module, push-pull topology is preferred, due to the fact; it has a better efficiency in comparison with other technologies. The module receives a positive continuous voltage about 5-8 V as input, and provides a programmable positive or negative continuous voltage from 800-2500 V as output for a total load of 200-KΩ. The ripple of the output voltage is 10 mV that it is measured by laboratory equipment's and safe high voltage (SHV) probe. The measured output power in the designed module is 25 W. Experiment results show that minimum efficiency at full load is around 65%. The proposed HV module shows a good stability, low ripple (noise), fast rise time. So, it can be used in SPECT or gamma camera imaging system to provide the constant voltage for PMTS.</p>
<p>Keywords: High Voltage, Stability, Efficiency, SPECT Systems, Voltage Ripple</p>	

1. INTRODUCTION

An essential part of the many nuclear imaging system is switching high voltage power supply (SHVPS) [5] that widely used in medicine, spectroscopy and pulse-power applications [1-2,3]. It is well known that having a high voltage with minimum ripple for supplying Photo Multiplier Tubes (PMTs) in Gamma camera systems is mandatory [7]. The ripple of applied voltage can influence image quality and lead to blur the reconstructed image [6]. In this study, a high voltage module with a voltage range from 800 to 2500 V at a 200-K Ω load with low ripple and fast rise time has been designed and constructed.

The magnitude of output ripple is proportional to load current. To achieve maximum Signal to Noise Ratio (SNR), output voltage ripple is less than 10 mV. It should be noted that, the designer must guarantee the stability of system during start up, the control unit is equipped with soft start up method, this methodology is a good choice when the stability and robustness of the system are important issues [4].

* Corresponding Author: M. Moradi
 Department of Medicine Engineering, Shahid Beheshti University, Tehran, Iran



2. MATERIALS AND METHODS

2.1. PMT Gain and High Voltage Ripple

Increasing high voltage increases the kinetic energy of electrons impacting dynode increases amplification factor d according to Eq. (1)

$$d \cong e^V \tag{1}$$

$$g_i = \delta_i * n_i \tag{2}$$

$$M = \prod_{i=1}^N g_i \tag{3}$$

Where g_i is gain of dynode i , δ_i is secondary emission factor of dynode i , n_i is collection efficiency of dynode i , N is the total number of the stage and M is a total gain of the multiplier [7]. For example, if g factor per dynode be 2 times and total number of stages be 10, the total gain of multiplier is:

$$M = 2^{10} \approx 1000 \tag{4}$$

This means that any fluctuation in applied voltage changes the gain by the amplification factor nearby 1000 (see Eq. (4)). Figure.1 illustrates this issue.

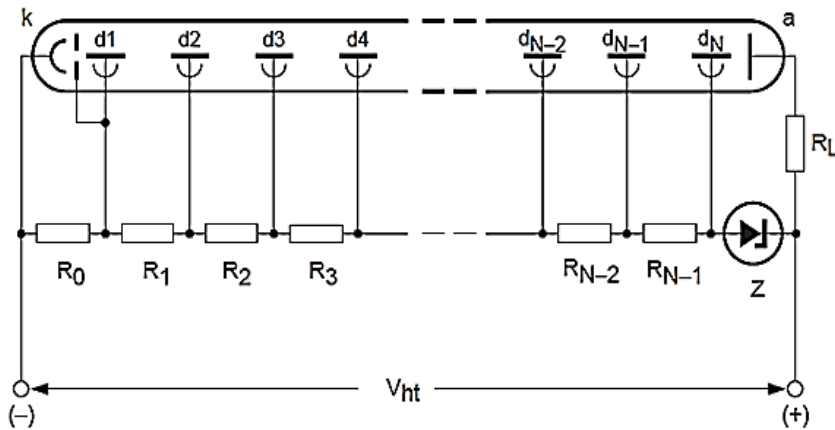

Fig. 1. Voltage-divider high-tension supply with Zener diode for improved linearity [7]

2.2. Circuit Description

For proper analysis in this study, the software’s PROTEUS, MULTISIM, and MATLAB were used. The switching high voltage power supply (SHVPS) receives an input signal of the type 5-8 V DC, which the timer circuit afterwards shapes as pulses. The frequency and duty cycle are chosen to promote effective switching operation. The two input pins of the comparators are passed the output of the pulse width modulation (PWM) circuit. The four voltage comparators will produce two distinct output signals that are mirror images of one another. A signal is transmitted to each switching device individually. BJTs are used as a source of high current in order to drive the DBPT into switching in a very short amount of time. A general transformer performs the crucial task of converting the DC signal from the switching device into an AC signal. For the purpose of power conversion, matching frequency and duty cycle must be established for push-pull transformers in common usage. 3000 VAC is generated during this

step up transformer operation. The rectifier circuit is then supplied with the AC signal. By adding diodes to a network and using an RC filter to eliminate ripple, the circuit is capable of converting AC electrical power from the transformer to a DC voltage. The output end of the power supply is connected in series with the feedback pin of the comparators by a feedback circuit made consisting of resistors. It generates the desired system response by monitoring the output and comparing it to a chosen reference voltage to provide negative feedback. Therefore, by altering the reference voltage, any required output voltage may be set manually or electronically. Figure.2 and 3 shows the schematic of power supply by MULTISIM 12.0 and MATLAB R2010 software's.

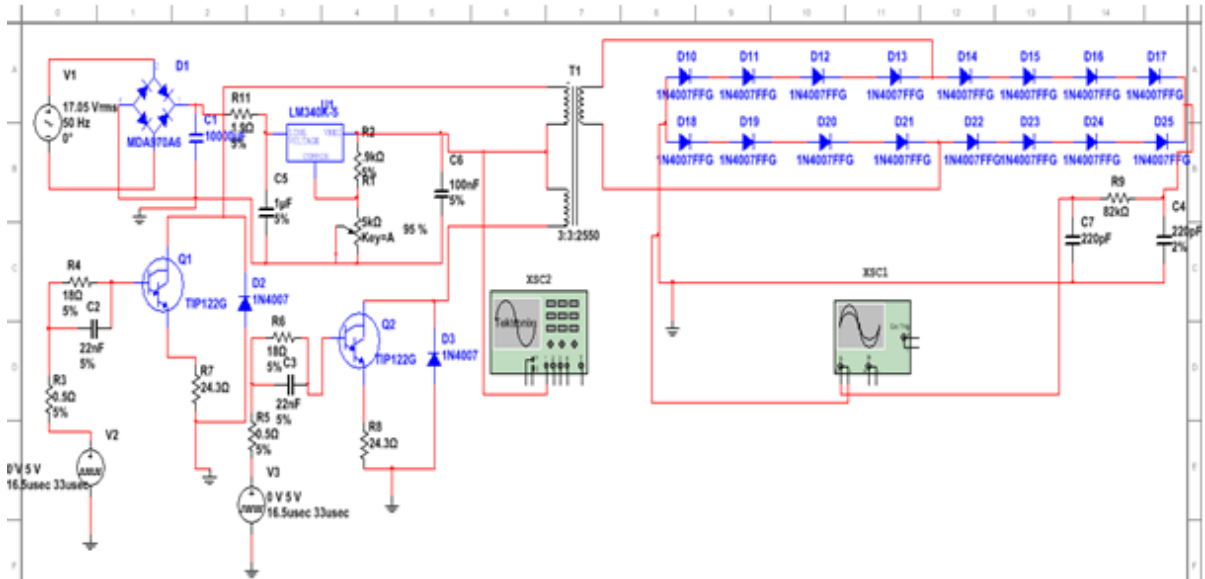

Fig. 2. Schematic of power supply by MULTISIM 12.0

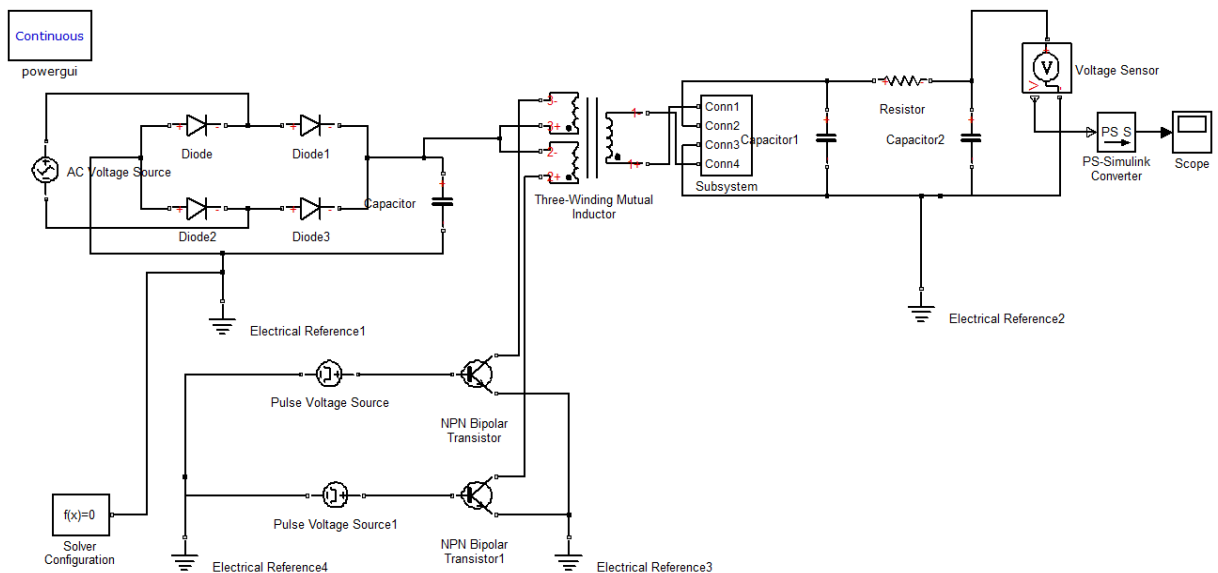

Fig. 3. Schematic of designed power supply by MATLAB R2010

3. RESULTS

3.1. Ripple Reduction

The SHVPS is created and constructed in accordance with the previously given standards, and simulation and experimentation are used to evaluate its performance. About 31 kHz is the SHVPS's nominal frequency, which is attained at 50% duty cycle. The values of the components, such as a capacitive filter (C_o), transformer turn ratio (n) and maximum current at full load (I_L) are $C_o = 150$ nF, $n = 400$, $I_o = 10$ mA.

The input pulses to trigger the transformer is shown in Fig.4 and 5, Fig.6 also presents experimental and simulated waveforms of outputs that are without and with filter capacitors, respectively. High voltage, low current of 10 mA, and a maximum power of 25 W were all produced by the power supply. This established low ripple about 10 mV (Figure.7) As soon as change in output voltage response due to load changing, feedback unit senses the difference of between sensed voltage and referenced voltage and apply it to PI controller then a controlled voltage send to the PWM unit to drive the power transistors. Fig.8 shows the transient response of SHVPS under close loop condition for step and impulse inputs, this Figure presents the stability analysis of SHVPS too, for overcome to instability problem added extra pole in pole-zero graph by PI controller (Fig.8).

From the simulated waveforms, it can be found that under closed loop condition the SHVPS should operate ideally. Comparison of controlling signal with output voltage that they are attained through simulation and experiment is shown in Fig.9.

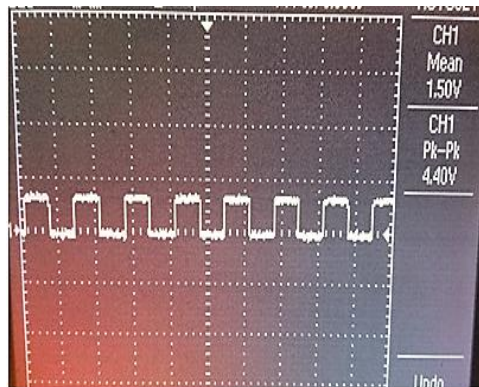

Fig.4. Input pulses for power transistor

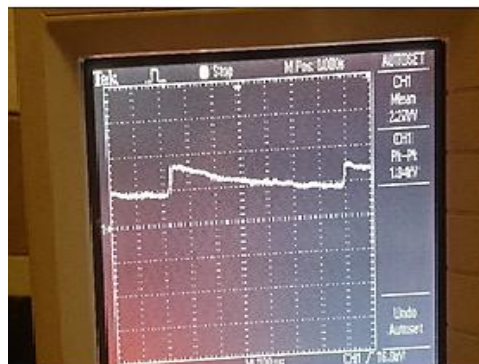

Fig.5. Rectified output voltage without filter and feedback unit



Fig.6. Rectified output voltage in software analysis.

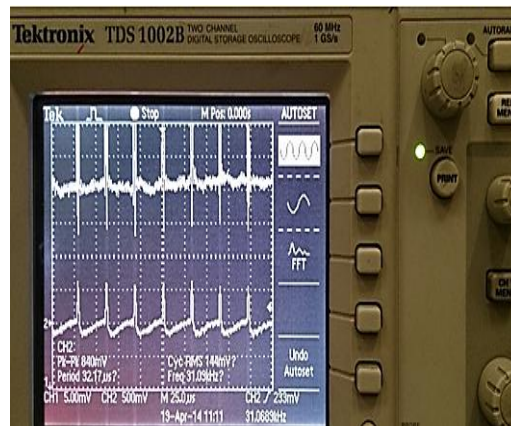

Fig.7. DC voltage of 2 KV produced by the power supply

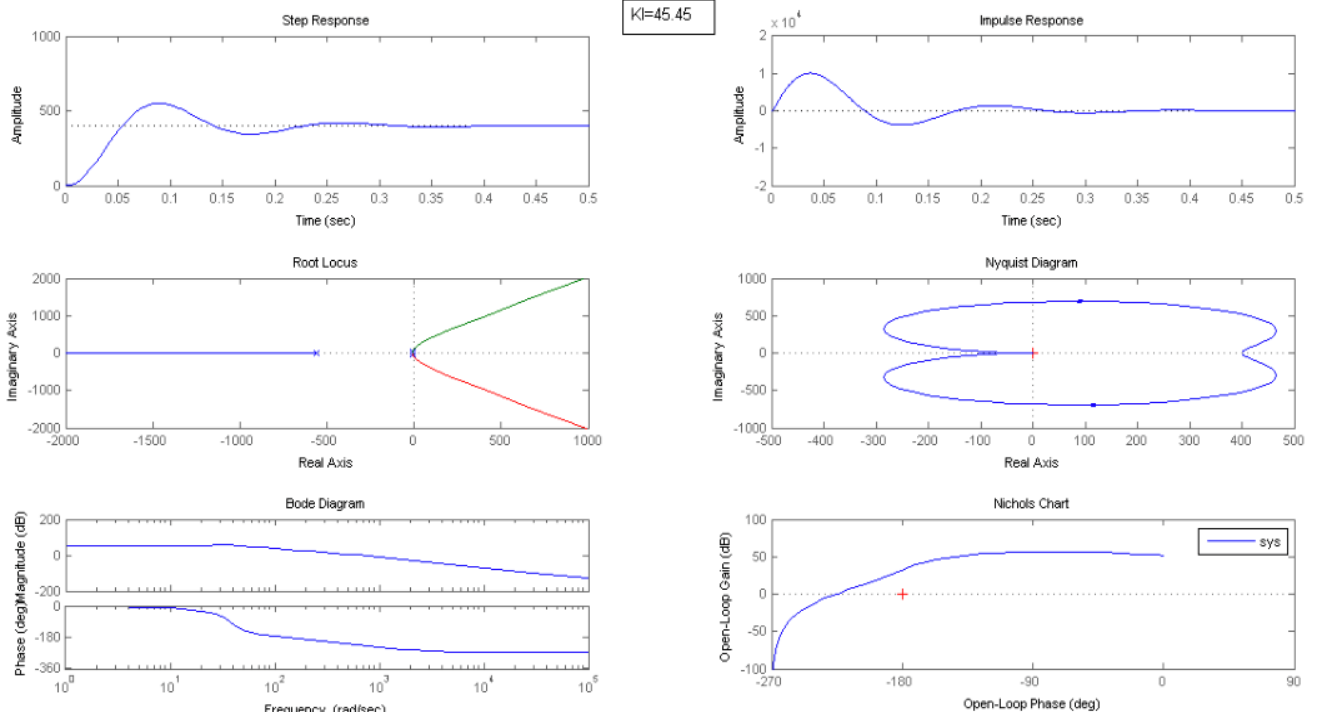

Fig. 8. Close loop response analysis by MATLAB R2010.

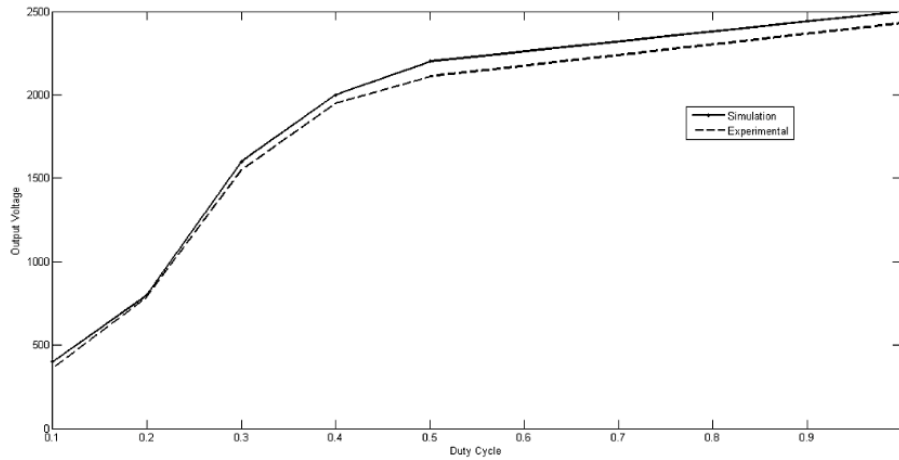

Fig. 9. Control to output characteristic.

3.2. Temperature Test

The power supply voltage can work at different temperatures to maintain a good level. This matter is important due to it able to work in the different situation, different installation locations and exist of adjacent devices that can degrade the performance of SHVPS. Thermal stability of supply will be determined by a number called the Output temperature coefficient. Temperature test is very important because of it can show the changes of output voltage and efficiency of module in proportional to the temperature changes. Table 1 shows the measured data for this test. In Fig.10 and Fig.11 show temperature test results for proposed module, too.

Table 1. The resulting of accomplished temperature test on the module.

Temperature (°C)	25	35	40	45	50	55	60	65
V_{OUT} (V)	1000	934	829	723	700	698	675	647
Efficiency (%)	67	63	62	48	47	46	45	43

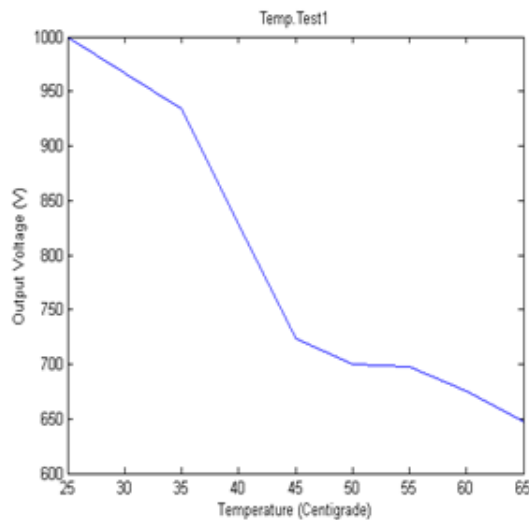

Fig. 10. Changing of Output voltage Vs. Temperature.

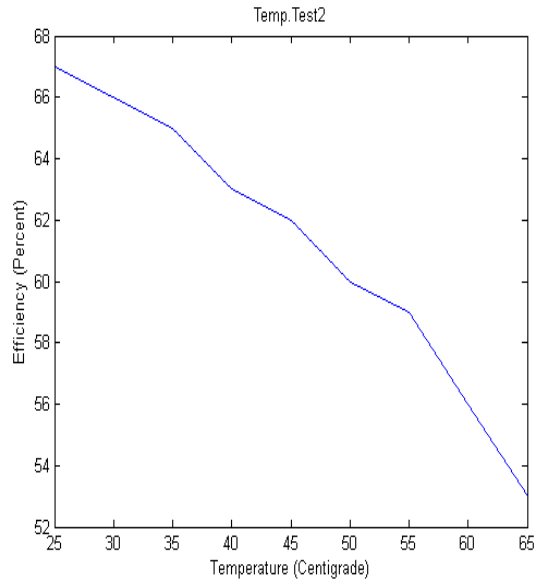

Fig. 11. Changing of Efficiency Vs. Temperature.

3.3. Voltage Stability

It is very important that output voltage of power supply be constant (acceptable) against of the changes the output load. Constant the output voltage of power supply with output current changes called the load regulation. It means that the power supply under various loads (from 10% to 100%), has the constant output voltage. For power supplies with a good line regulation, the error rate is less than $\pm 0.5\%$. As the impedance of photo multiplier tube that used here is $200\text{ k}\Omega$ approximately, the output voltage changes performed with software analysis in 10%, 50% and 100% of the output load and with initial voltage of 1000 V that have been shown in figure 12, figure 13 and figure 14.

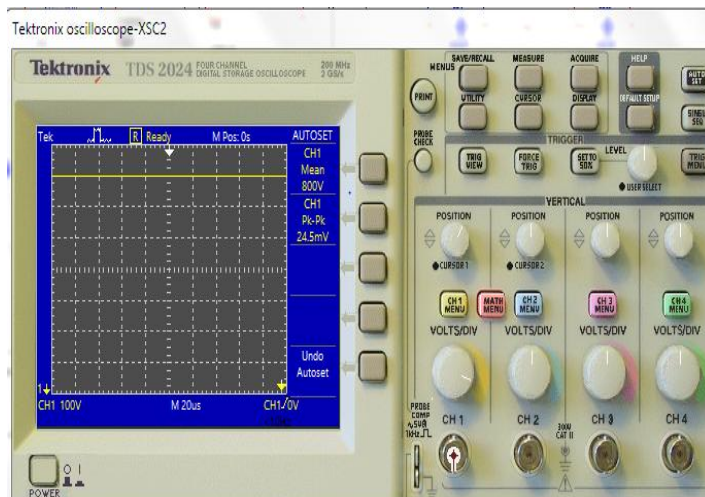

Fig. 12. Output voltage changes at 10% of nominal load

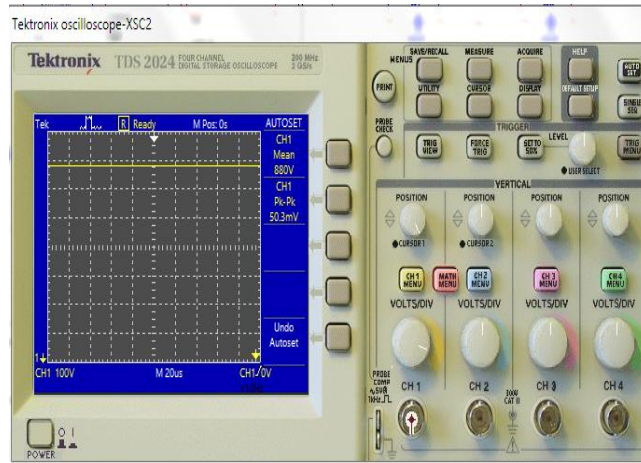

Fig. 13. Output voltage changes at 50% of nominal load.

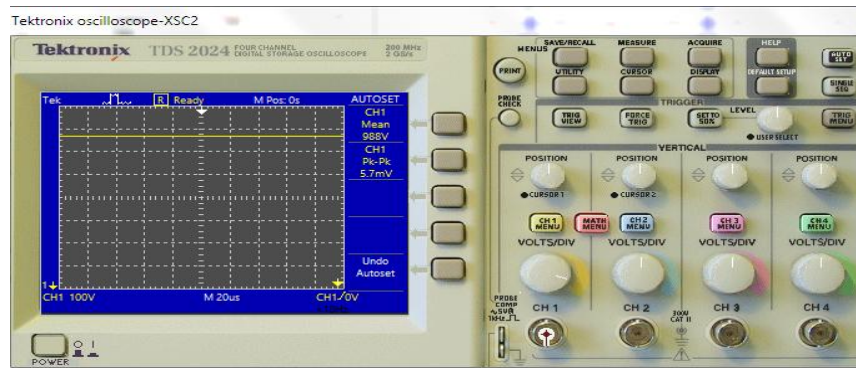

Fig. 14. Output voltage changes at 100% of nominal load.

Table 2. Comparison between fabricated SHVPS and C11323 model of Hamamatsu.

Parameter	Proposed SHVPS	Hamamatsu [7]	Unit
Voltage Input	+5 - +15	+20 - +25	V
Current Input	1.75	1.7	A
Guaranteed Output Voltage Range	500 - 2500	300 - 1800	V
Ripple (Pk-Pk)	10	40	mV
Output Voltage Control	0 - +5	0 - +6	V
Output Voltage Rise Time	35	100	ms
Line Regulation	20	5	%
Efficiency	65	80	%
Weight	Approx.450	Approx.230	g

4. DISCUSSION AND CONCLUSION

The control circuit for this SHVPS is selected under various line, pulse load condition and fast rise time response. The rise time is found about 35 ms and line regulation is less than 0.2. As the SHVPS is switched at half the pulse load frequency under HV, transformer insulation must be safe from failure, so is used from NOMEX insulator. The efficiency of the SHVPS is greater than 65% in the guaranteed voltage range that it can be improved by digitalizing

of the module. In future works, has been decided to digitalizing the SHVPS using a microcontroller. Optimizing work for this module occurred at $<50^{\circ}\text{C}$ and increasing in temperature led to decreasing in output voltage and efficiency. Specifications of proposed SHVPS and a same type (C11323 model of Hamamatsu [7]) have been shown in the table 2.

5. ACKNOWLEDGMENT

This work supported by Shahid Beheshti University and Research Center for Molecular and Cellular Imaging, Tehran University of Medical Sciences, Tehran, Iran.

CONFLICTS OF INTEREST

The authors declare no conflict of interest.

REFERENCES

- [1] Xi, W., Seidel, J., Kakareka, J. W., Pohida, T. J., Milenic, D. E., Proffitt, J., ... Choyke, P. L. (2010). MONICA: A compact, portable dual gamma camera system for mouse whole-body imaging. *Nuclear Medicine and Biology*, 37(3), 245–253. <https://doi.org/10.1016/j.nucmedbio.2009.12.003>
- [2] D'Antone, I., Lolli, M., & Zanotti, M. (2002). High voltage generator for the power supply of photomultipliers in the time-of-flight system of Alpha Magnetic Spectrometer-2 experiment. *Nuclear Instruments and Methods in Physics Research Section A: Accelerators, Spectrometers, Detectors and Associated Equipment*, 480(2–3), 555–564. [https://doi.org/10.1016/S0168-9002\(01\)01222-0](https://doi.org/10.1016/S0168-9002(01)01222-0)
- [3] Vishwanathan, N., & Ramanarayanan, V. (2004). *High voltage DC power supply topology for pulsed load applications with converter switching synchronized to load pulses* [Paper presentation]. The Fifth International Conference on Power Electronics and Drive Systems, Singapore. <https://doi.org/10.1109/peds.2003.1282930>
- [4] Rubino, L., & Marino, P. (2012, May). *Unified supervised soft start-up and digital PI control for boost full-bridge converters* [Paper presentation]. 2012 IEEE 21st International Symposium on Industrial Electronics (ISIE), Hangzhou, China. <https://doi.org/10.1109/isie.2012.6237150>
- [5] Knoll, G. F. (2021). *Radiation detection and measurement* (5th ed.). John Wiley & Sons.
- [6] Maher, K. (2006). *Basic physics of nuclear medicine*. Libronomia Company.
- [7] Flyckt, S. O. (2002). *Photomultiplier tubes: Principles and applications*. Photonis.