



Interior Permanent Magnet Induction Motor Design Considerations

M. Shiravi^{1,*}, H. Maleki², S. Amir³, M. H. Ranjbari⁴

¹Department of Electrical Engineering, Kashan University, Kashan, Iran

²Department of Engineering, Islamic Azad University, Sama, Khomeinishahr, Iran

³Department of Mechanical Engineering, Kashan University, Kashan, Iran

⁴Department of Electrical Engineering, Lorestan University, Lorestan, Iran

ARTICLE INFO	ABSTRACT
<p>Article History: Received 18 December 2020 Received in revised form 11 January 2021 Accepted 9 March 2021 Available online 10 March 2021</p>	<p>The design and simulation of electric machines—such as Induction Machines (IMs) and Interior Permanent Magnet (IPM) motors—can be significantly optimized in terms of both time and cost by applying certain strategic techniques within Ansys Maxwell software. This paper presents a structured, step-by-step methodology for the laboratory-scale design and simulation of an IM, emphasizing best practices that streamline the modeling process. A transient solver is selected as the simulation type due to its suitability for capturing dynamic electromagnetic behavior, although it is computationally intensive. The study further explores the integration of U-shaped permanent magnets within the rotor yoke of an IPM motor, analyzing the impact of this unique configuration on machine performance. The design and simulation results confirm the feasibility of testing and evaluating various motor parameters under realistic conditions. Notably, although the U-shaped magnet configuration introduces geometric and computational complexity, its successful implementation suggests that alternative and potentially simpler structures can be simulated with relative ease. The approach outlined in this study provides a practical reference for engineers and researchers engaged in electric motor design, enabling more efficient modeling and analysis of complex machine architectures using commercial finite element analysis tools.</p>
<p>Keywords: Induction Motor (IM), Permanent Magnet synchronous Motors (PMSMs), Interior Permanent Magnet (IPM), Line Start Permanent Magnet (LSPM), Finite Element Method (FEM)</p>	

1. INTRODUCTION

Main idea of this article is introducing to produce some techniques for rotary machines in Ansys Maxwell [1], so we foresee that reader will be found this an applied paper. Therefore, this means that Ansys Maxwell procedure design of IM and LSPM is main part of this paper. Many research shows that torque per volume and output characteristic of IPM is improved versus IM [2-4]. Especially the efficiency is greatly affected by shape of the permanent magnet installed inside the rotor [5-7]. So here u-shape configuration is selected which more complicated versus other structures. This research takes so much times to be done and finally achieved results is satisfactory.

* Corresponding Author: M. Shiravi

Department of Electrical Engineering, Kashan University, Kashan, Iran



First, an IM is selected that its picture is shown in figure 1 and figure 2. Motor developed power is 3 (hp), 4 poles. And its synchronous speed is 50π (rad/sec). So its developed torque is 14 (N.m). Based on figure 2, number of stator and rotor slots, respectively is 36 and 28 and its copper winding isn't seen and stator has 36/3/4 slots in each phase/pole and so $q=3$.

After measurement, dimension sizes is inserted in table 1. I know that it is permissible to set air-gap in this interval:

$g \leq \text{airgap} \leq 2g$; Where g is the best gap. At next step, a new Maxwell 2D design (transient, XY) is created which is shown in figure 3; all techniques it's that 2D modeler draw wire is used. Based on this method through the drawing, it's possible to right-click and then click on "set edge type" option and desired wire is selected. So it should be possible to draw accurately complicated shapes. Next, its solution type and geometry mode is selected respectively transient and Cartesian. And a thick aluminum skin is covered round of machine. A circle around 2D design is drawn, next the edge of circle is selected and its material is assigned as vacuum and then boundary is assigned as balloon 1.

And next, its material that is inserted in table 2 is assigned. BH curve of steel_1008 is shown in figure 4. For each stator slot should be assigned excitation as coil with parameter: 44 conductor and positive or negative current polarity, three slot positive other three negative. Every 12 coil should be add to one winding, we select every 3 other 6. So we have 3 windings. Then all 28 rotor coil should be selected and assigned as excitation as end-connection. This means rotor short circuit. External circuit which I have setup in my model which is shown in Figure 5. With each winding one resistance and inductor is connected. In each stator winding: $L=0.05(\text{mH})$, $R=1(\text{ohm})$. For each rotor winding: $L=0.084(\text{uH})$, $R=1.5(\text{uohm})$ and each end-connection $L=0.05(\text{uH})$, $R=1(\text{uohm})$. Next, rotor should be selected on model and assigned motion setup with: motion type as rotation, mechanical with consider transient: moment of inertia: 0.005 kg.m^2 : this value is very important in all domain of machine design, So if it will be very big or very small, accurate response isn't achieved, e.g. torque will be periodically positive and negative which isn't desired; initial angular velocity: 0; damping: 0; load torque: 0. Now, I draw a circle around rotor through air-gap and assign vacuum material and assign parameters as force1, torque 1. Next, mesh operation inside selection should be assigned: consider length of element: enabled, 18(mm), do not consider number of element. Now, I add solution (analysis) setup: enabled, stop time: 0.01(sec), step time: 0.005(sec); save field: linear, start: 0, stop: 0.01, step: 0.05 and add to list. Demagnetization option with nonlinear BH curve; solver: nonlinear residual: 0.0001, time integration method: Backward Euler; expression cache: is not available until after its solution has been created.



Fig. 1. Rotor stack and its layer cut.

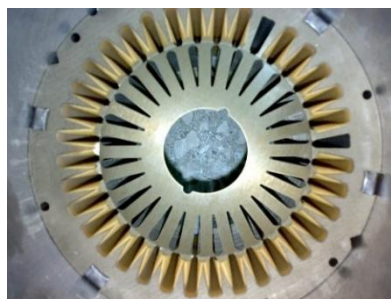

Fig. 2. IM cross section without shaft.

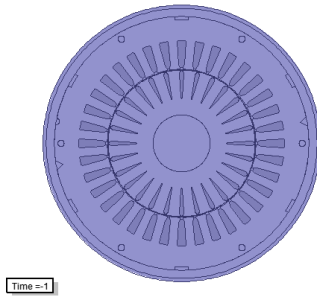

Fig. 3. Maxwell 2D design (transient, XY)

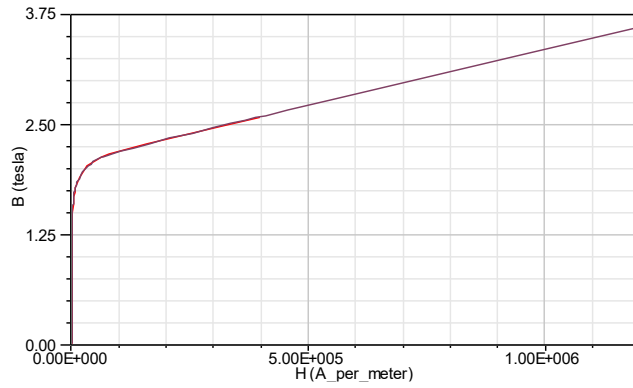

Fig. 4. BH curve for steel_1008

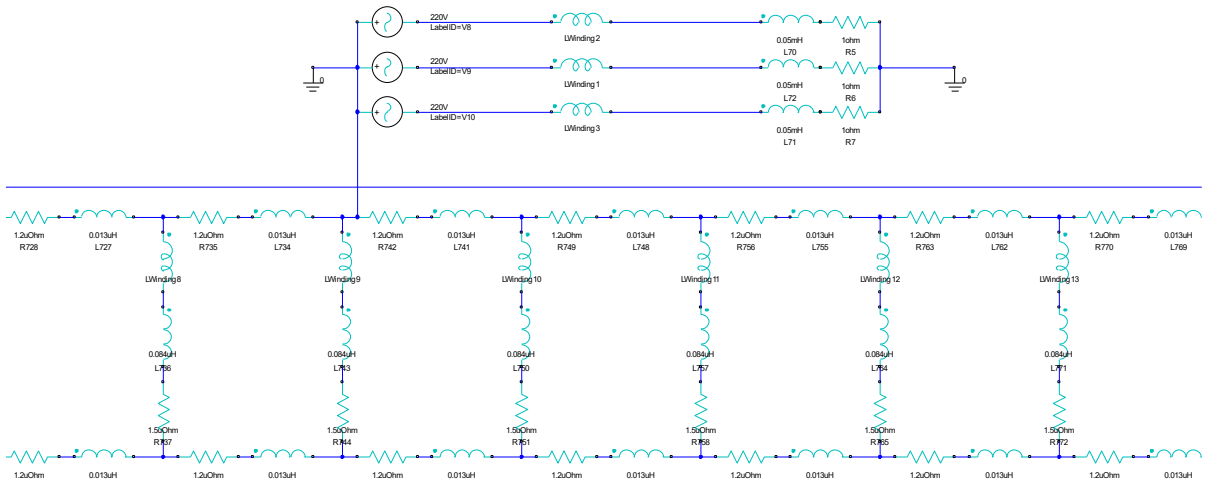

Fig. 5. External circuit for excitation. Rotor section part is extended at two sides up to 28 winding.

Table 1. Parameter values chosen during measurement, simulation and design

Subunit	IR(mm)	OR(mm)
Stator Back iron	17.5	27.5
Rotor Tooth/Winding	27.5	45
Air Gap	45	45.6
Stator Tooth/Winding	45.6	63.1
Stator Back iron	63.1	78

Table 1. Materials for Induction Motor

Subunit	Material	Properties
Stator/Rotor Back iron	Steel_1008	<i>BH curve</i>
Stator/Rotor Winding	copper	<i>Relative permeability $\mu_r = 1$</i>

2. SIMULATION RESULTS

At first, it should be say that it’s consumed very much times to produce this excellent results. After all arrangements and settings, I use validation check and with no error and warnings detection, now it is the time to analyze all. This part take many times; so it depends on computer system configuration so as: processor, video card, hard drive space, RAM and operating system (windows version).

2.1. Induction motor

Based on figure 6, Distribution of magnetic field density at edge of stator teeth approximately is 2 tesla. And position of poles at this moment is seen. Rotor position, speed and developed torque respectively is seen in Figure 7, 8, 9. Nearly, at .65 (sec) motor reach the synchronous speed at no load and in continue, it has an epsilon alteration around this point. Torque transient states is seen in figure 9.

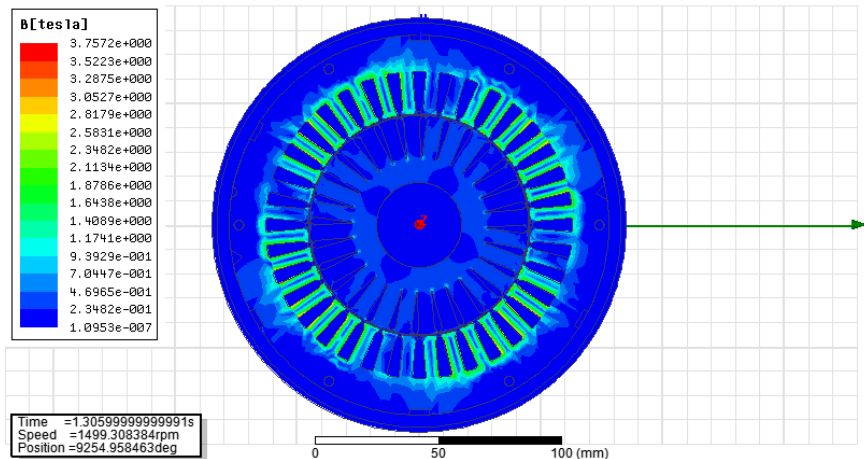

Fig. 6. Distribution of magnetic field density at analysis time.

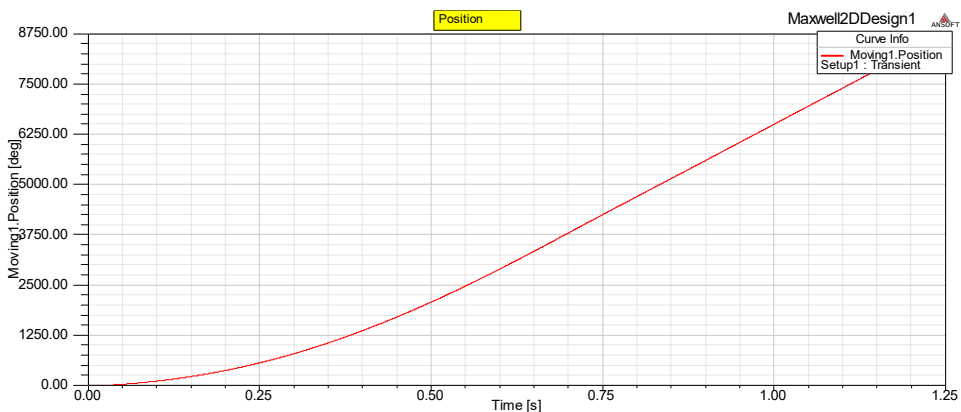

Fig. 7. Rotor position.

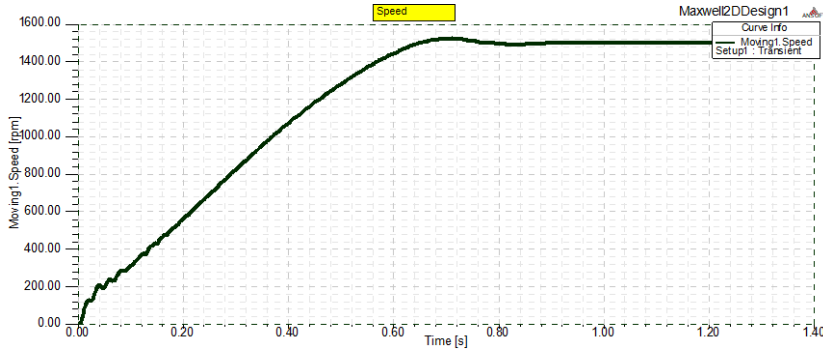

Fig. 8. Rotor speed which is considered for normal operating.

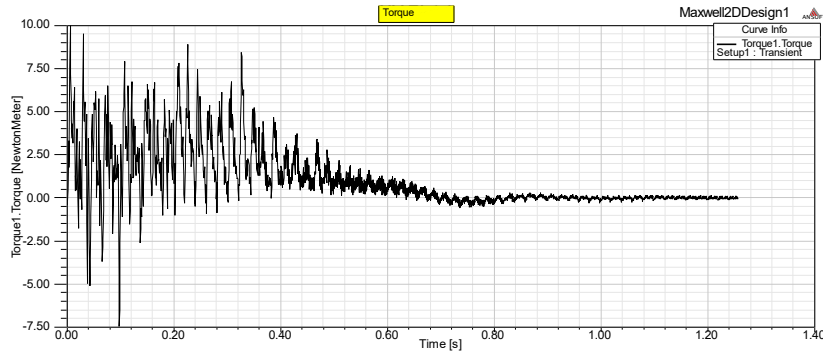

Fig. 9. Developed torque at no load.

2.2. Internal permanent magnet IM or LSPM

Open U-type magnet is placed symmetrically in rotor yoke (is shown in figure 10). To produce more developed torque per volume I test here three operation modes based on load torque for LSPM (is seen in table 3 and figure 15, 16). Difference of distribution of magnetic field density of this part is seen obviously versus previous part (figure 11, 12). There is more magnetic field density in rotor versus previous part. Variation of operation point is seen in torque- speed curve. At beginning, machine has a transient states. Motor torque versus its load is seen in figure 14. Motor reach its steady state point at less time (nearly 125 (msec) at figure 15). There is more speed variation in third mode. Torque versus time for three modes is seen in figure 16.

All of this procedure was done for surface-type magnet which symmetrically placed on 4 position of surface of rotor. In this case better result was achieved; so as less torque ripple, less speed ripple, more efficiency. Results isn't shown here.

Table 2. Operation modes of internal permanent magnet Induction Motor.

mode	Ext. Rotor winding	Inertia (kg/sec ²)	Load torque (N.m)		P.M& shaft
latter	Ok	.03	0		Ok
third	Ok	.03	+14		Ok
forth	Ok	.03	-14	Ok	

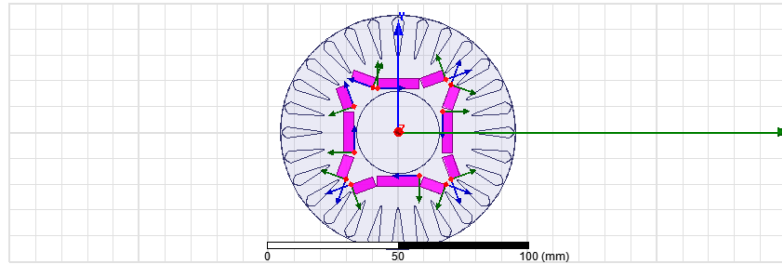

Fig. 10. View of magnets and its coordination system.

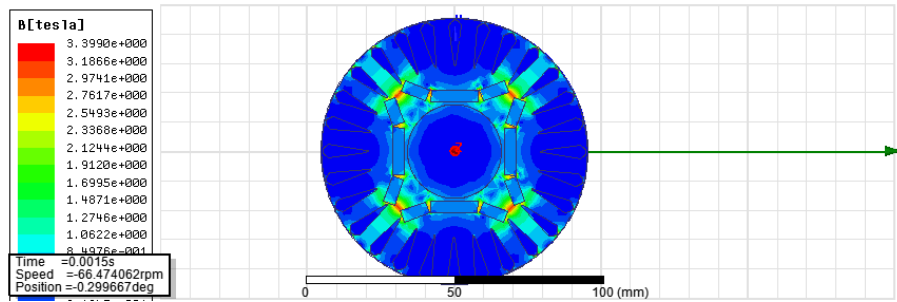

Fig. 11. Distribution magnetic field density in rotor cross section of LSPM.

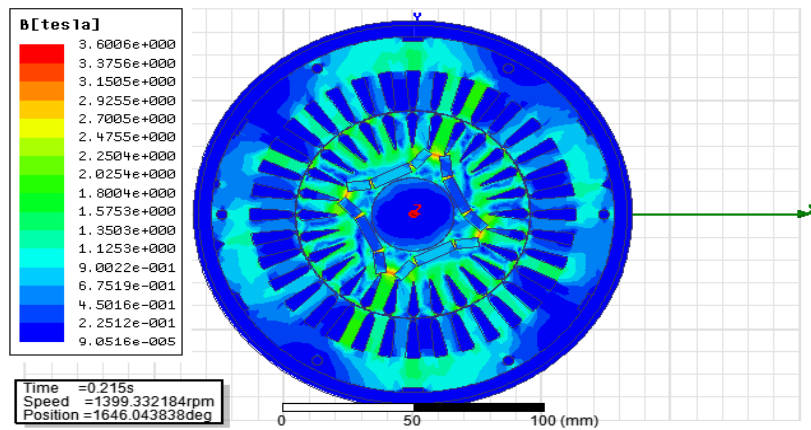

Fig. 12. Distribution magnetic field density in rotor and stator cross section of LSPM.

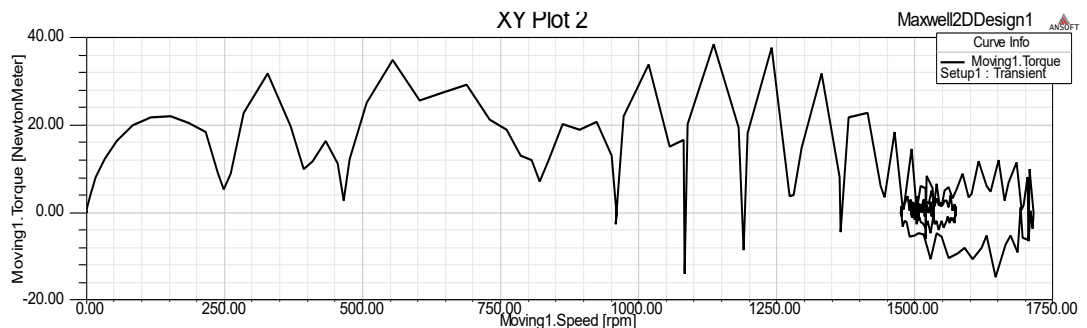

Fig. 13. Torque- speed curve

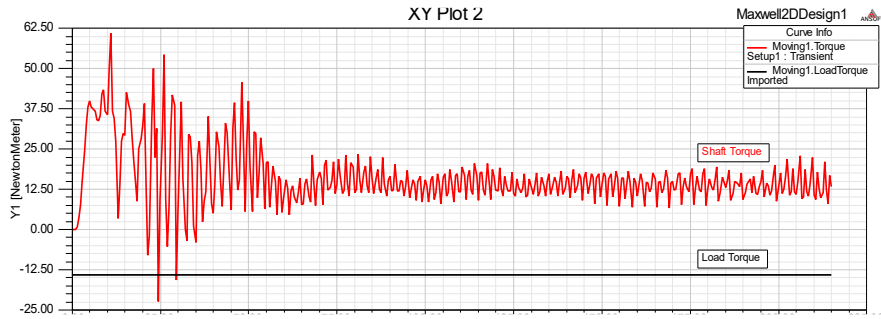

Fig. 14. Torque versus time

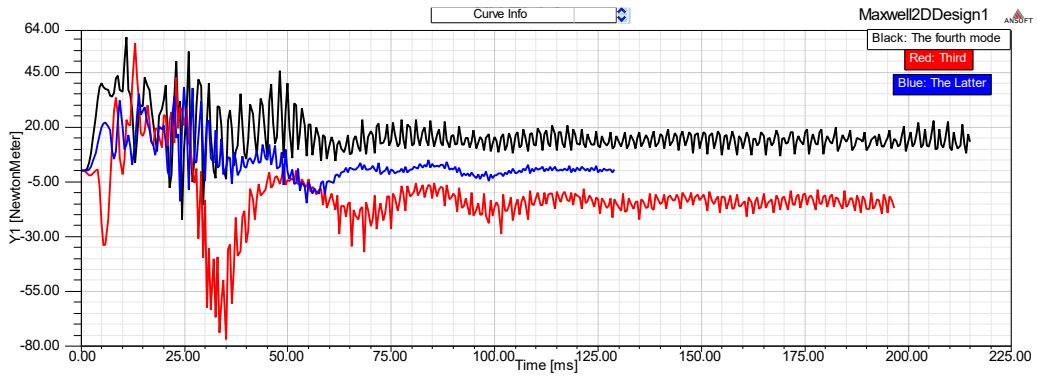

Fig. 15. Speed versus time for three modes.

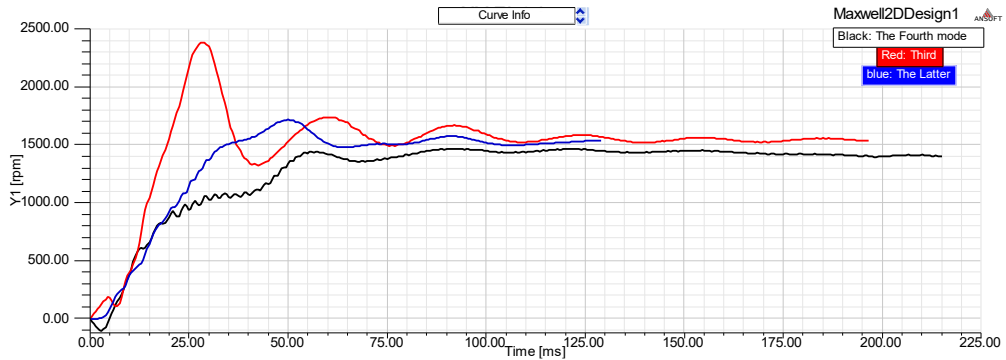

Fig. 16. Torque versus time for three modes.

3. CONCLUSIONS

First an induction motor 3hp power output is selected, all components of machine is opened and all dimension are measured. Air gap is considered greater than 0.35 (mm) for inhabitation of unbalanced pull magnetization (UPM). Then stator, rotor, stator slot, rotor slot, skin, shaft, stator and rotor coils is drawn. Then material is assigned. Next solution type, unit, analyze setup, parameters and mesh size are added. Then excitation of stator and rotor coils are assigned. Finally results are extracted.

In second step, U-shape is subtracted from rotor yoke and U-PM is added. And its material is assigned to NdFe35. And transient solution is analyzed. So sketch all is designed by hand and Rotational Machine Expert (RMxprt) wizard is not used. This ability is useful to design special machine which isn't defined in RMxprt.

CONFLICTS OF INTEREST

The authors declare no conflict of interest.

REFERENCES

- [1] ANSYS Inc. (n.d.). Maxwell 3D Field Simulator v16: User's Guide. ANSYS Inc.
- [2] Choi, J. S., Izui, K., Nishiwaki, S., Kawamoto, A., & Nomura, T. (2012). Rotor pole design of IPM motors for a sinusoidal air-gap flux density distribution. *Structural and Multidisciplinary Optimization*, 46(3), 445–455. <https://doi.org/10.1007/s00158-012-0774-8>
- [3] Morimoto, S., Takeda, Y., & Hirasaka, T. (1993). Parameter measurement of PM motor in dq equivalent circuit. *IEEJ Transactions on Industry Applications*, 113(11), 1330–1331. <https://doi.org/10.1541/ieejias.113.1330>
- [4] Lavrinoviča, L., & Dirba, J. (2014). Comparison of permanent magnet synchronous motor and synchronous reluctance motor based on their torque per unit volume. In *2014 Electric Power Quality and Supply Reliability Conference (PQ)* (pp. 233–236). IEEE. <https://doi.org/10.1109/PQ.2014.6866817>
- [5] Fratta, A., & Vagati, F. (1990). Design criteria of an IPM machine suitable for field-weakened operation. In *Proceedings of the International Conference on Electrical Machines* (pp. 1059–1065).
- [6] Yokote, H., & Higaki, T. (1996). Magnet arrangements and output characteristics of multi-layer interior PM motors. In *Rotary Machines Study Group, IEE Japan* (pp. 96–118).
- [7] Takeda, H., & Narazaki, M. (1995). Comparison of characteristics by rotor structures of IPM motors. *Rotary Machines Study Group, IEE Japan*.